

Splitters

PRO SPLITTER 5 DS 50

Passive 1-In / 5-Out Signal Splitter with
Extended Dynamic Range



- Line level splitter sends single input signal to 5 outputs
- High headroom design offers superior sound quality
- Passive design does not require any power supply
- High quality Neutrik* XLR connectors
- Ultra-low noise and ultra-linear system for highest signal integrity
- Aluminium extrusion casing with protective rubber corners
- Compact and rugged design
- 10-Year Warranty Program*
- Designed and engineered in the U.K.

Building on KLARK TEKNIK's storied legacy of highest-quality signal processing devices, the DS 50 PRO SPLITTER 5 offers the same high headroom, dynamic response and sonic clarity you have come to expect. DS 50 is ideal for routing balanced XLR signals to as many as 5 discrete destinations, including FOH and monitor consoles, active monitor loudspeakers, broadcast mixers, and more. A passive device, the DS 50 does not require any form of external power, making it the perfect solution for a wide range of professional audio and multimedia applications.

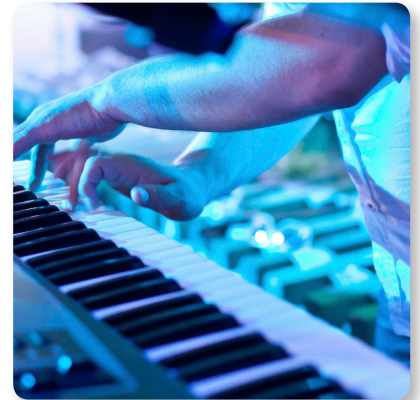

High Headroom Design

A custom instrumentation-grade input circuit was designed for the DS 50 using advanced analogue design techniques to create the ideal input impedance match. This innovative approach provides an ultra low noise and ultra-linear system with a ruler-flat frequency response that ranges from 20 Hz to 22 kHz (± 0.05 dB).



*All third-party trademarks are the property of their respective owners. Their use neither constitutes a claim of the trademark nor affiliation of the trademark owners with MUSIC Tribe. Product names are mentioned solely as a reference for compatibility, effects and/or components. Warranty details can be found at musictribe.be.

Splitters

PRO SPLITTER 5 DS 50

Passive 1-In / 5-Out Signal Splitter with
Extended Dynamic Range

Connectivity

All of the Input and Output connections on the DS 50 feature genuine high quality Neutrik* XLR jacks for the ultimate in signal integrity.



Compact & Rugged Construction

The ultra-compact DS 50 is built to handle the rigours of life on the road via a thick and rugged aluminium extrusion that protects the electronics. The enclosure's roadworthiness is further enhanced through the implementation of sturdy rubber corner bumpers.

Versatility

The DS 50 PRO SPLITTER 5 allows you to send identical copies of balanced input signals to up to 5 discrete destinations thanks to its incredible frequency response of 20 Hz to 22 kHz (± 0.05 dB) and highly intuitive design – all in a road-ready enclosure that stands ready for your input.

Visit your local **KLARKTEKNIK** supplier to try out the DS 50 PRO SPLITTER 5, or get yours online today. Your ears can tell the difference...



Splitters

PRO SPLITTER 5 DS 50

Passive 1-In / 5-Out Signal Splitter with
Extended Dynamic Range



You Are Covered

We always strive to provide the best possible Customer Experience. Our products are made in our own [MUSIC Tribe](#) factory using state-of-the-art automation, enhanced production workflows and quality assurance labs with the most sophisticated test equipment available in the world. As a result, we have one of the lowest product failure rates in the industry, and we confidently back it up with a generous [Warranty program](#).

Splitters

PRO SPLITTER 5

DS 50

Passive 1-In / 5-Out Signal Splitter with Extended Dynamic Range

Dimensions

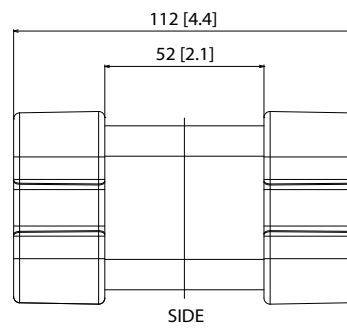
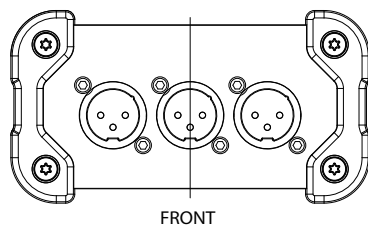
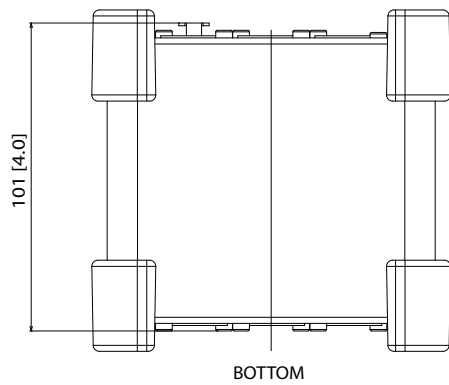
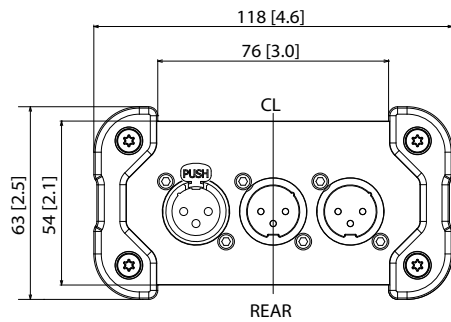

Splitters

PRO SPLITTER 5 DS 50

Passive 1-In / 5-Out Signal Splitter with
Extended Dynamic Range

Technical Specifications

Inputs

Connector	XLR, balanced
-----------	---------------

Outputs

Connectors	5 x XLR, balanced
------------	-------------------

System

Frequency response	20 Hz to 22 kHz (± 0.05 dB)
--------------------	----------------------------------

THD + N (distortion)	< 0.01% @ 1 kHz, +4 dBu
----------------------	-------------------------

Signal-to-noise ratio	121 dB
-----------------------	--------

CMRR	98 dB typical
------	---------------

Insertion loss	0.05 dB @ 100 k Ω , 0.7 dB @ 600 Ω
----------------	--

Power requirement	Passive
-------------------	---------

Physical

Dimensions (W x D x H)	118 x 112 x 64 mm (4.6 x 4.4 x 2.5")
------------------------	--------------------------------------

Weight	0.43 kg (0.9 lbs)
--------	-------------------

Splitters

PRO SPLITTER 5

DS 50

Passive 1-In / 5-Out Signal Splitter with
Extended Dynamic Range



Splitters

PRO SPLITTER 5 DS 50

Passive 1-In / 5-Out Signal Splitter with
Extended Dynamic Range



For service, support or more information contact the KLARK TEKNIK location nearest you:

Europe
MUSIC Tribe Brands UK Ltd.
Tel: +44156 273 2290
Email: CARECrea@music-group.com
CAREnte@music-group.com
CARELife@music-group.com

USA/Canada
MUSIC Tribe Commercial NV Inc.
Tel: +1 702 800 8290
Email: CARECrea@music-group.com
CAREnte@music-group.com
CARELife@music-group.com

Japan
MUSIC Tribe Services JP K.K.
Tel: +81 3 6231 0453
Email: CARECrea@music-group.com
CAREnte@music-group.com
CARELife@music-group.com

MUSIC Tribe accepts no liability for any loss which may be suffered by any person who relies either wholly or in part upon any description, photograph, or statement contained herein. Technical specifications, appearances and other information are subject to change without notice. All trademarks are the property of their respective owners. MIDAS, KLARK TEKNIK, LAB GRUPPEN, LAKE, TANNOY, TURBOSOUND, TC ELECTRONIC, TC HELICON, BEHRINGER, BUGERA and COOLAUDIO are trademarks or registered trademarks of MUSIC Tribe Global Brands Ltd. © MUSIC Tribe Global Brands Ltd. 2018 All rights reserved.