

Quick Start Guide

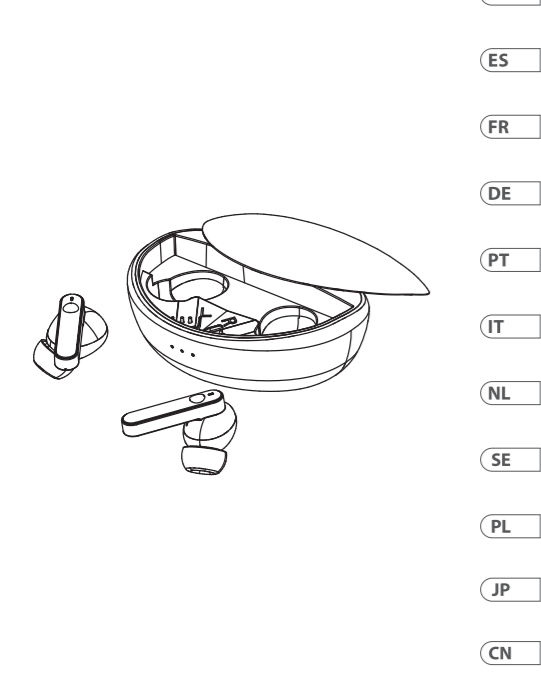

T-BUDS High-Fidelity True Wireless Stereo Earbuds with Bluetooth and Active Noise Cancellation



V 1.0

⚠️ Ważne informacje bezpieczeństwa

- Przeczytaj te instrukcje.
- Zachowaj te instrukcje.
- Zastosuj się do wszystkich ostrzeżeń.
- Zastosuj się do wszystkich zaleceń.
- Nie używaj tego urządzenia blisko wody.
- Czyść tylko suchą ścierką.
- Wyrzucenie baterii do ognia lub rozgrzanego pieca, albo mechaniczne zgniecenie lub rozcięcie baterii może spowodować wybuch.
- Pozostawienie baterii w środowisku o skrajnie wysokiej temperaturze może spowodować wybuch albo wyciek łatwopalnej cieczy lub gazu.
- Bateria poddana skrajnie niskiemu ciśnieniu powietrza może skutkować wybuchem albo wyciekiem łatwopalnej cieczy lub gazu.
- Nie należy rozbierać ani modyfikować tego produktu.
- Nie należy wymieniać baterii. Może to uszkodzić zabezpieczenie.
- Prosimy o przechowywanie tego produktu w czystym i suchym środowisku.
- Należy go ładować (przynajmniej) raz w miesiącu.
- Nie należy go pozostawiać bez nadzoru podczas ładowania.
- UWAGA!** Zagrożenie poknięciem i uduszeniem. Produkt należy trzymać bezpiecznie poza zasięgiem dzieci oraz zwierząt. Mały rozmiar oraz obecność wewnętrznej baterii stanowią niebezpieczeństwo poknięcia oraz uduszenia. Niezastosowanie się do instrukcji może spowodować trwały uraz lub śmierć.

⚠️ 重要な安全上の注意

- 使用上の注意をよくお読みください。
- 使用上の注意を保管しておいてください。
- 警告すべてにしたがってください。
- 使用上の指示すべてにしたがってください。
- 本装置を水の近くで使用しないでください。
- 必ず乾いた布でクリーニングしてください。
- バッテリーを火や熱い炉に投げたり、機械破砕や切断したりすると、爆発の危険があります。
- バッテリーを高温になる環境に置いておくと、爆発したり、可燃性の液体またはガスが漏れる恐れがあります。
- バッテリーは、気圧が極端に低い場所では爆発したり、可燃性の液体またはガスが漏れる恐れがあります。
- 本装置を分解したり改造したりしないでください。
- バッテリーを交換しないでください。安全装置が破損します。
- 製品を清潔で乾燥した環境で保管してください。
- 月に1回以上充電してください。
- 充電中はその場を離れないでください。
- 警告!** 窒息および誤飲の危険あり。本製品は、お子様やペットの届かない場所に保管してください。サイズが小さく、バッテリーを内蔵しており、窒息および誤飲の危険があります。本警告に従わない場合、永続的な障害や死亡の危険があります。

⚠️ Important Safety Information

- Read these instructions.
- Keep these instructions.
- Heed all warnings.
- Follow all instructions.
- Do not use this apparatus near water.
- Clean only with dry cloth.
- Disposal of a battery into fire or a hot oven, or mechanically crushing or cutting of a battery, can result in an explosion.
- Leaving a battery in an extremely high temperature surrounding environment can result in an explosion, or the leakage of flammable liquid or gas.
- A battery subjected to extremely low air pressure may result in an explosion or the leakage of flammable liquid or gas.
- Do not disassemble or modify this product.
- Do not replace a battery. It can defeat a safeguard
- Please store this product in a clean and dry environment.
- Charge it once a month (minimum).
- Do not leave unattended while charging.
- WARNING!** Choking and Swallowing Hazard. Keep the product safely out of reach of children and pets. The small size and the internal battery present a choking and swallowing hazard. Failure to follow instructions may lead to permanent damage or death.

⚠️ Información importante de seguridad

- Lea estas instrucciones.
- Conserve estas instrucciones.
- Preste atención a todos los avisos.
- Siga todo lo indicado en estas instrucciones.
- No utilice este aparato cerca del agua.
- Limpie este aparato sólo con un trapo suave y seco.
- El eliminar una pila tirándola a un fuego o un horno encendido, o el tratar de romperla o desmontarla mecánicamente puede dar lugar a una explosión.
- El dejar una pila en un entorno con una temperatura exterior extremadamente alta puede dar lugar a una explosión o a una fuga de un líquido o gas inflamable.
- Si una pila queda sujeta a una presión de aire extremadamente baja se puede producir una explosión o a una fuga de un líquido o gas inflamable.
- No trate de desmontar o modificar este aparato en forma alguna.
- No trate de sustituir la pila por sus propios medios. Puede anular su sistema de seguridad.
- Almacene este aparato en un entorno limpio y seco.
- Cárguelo como mínimo una vez al mes.
- No permita que este aparato quede desatendido durante el proceso de carga.
- ¡ATENCIÓN!** Riesgo de atragantamiento o ahogamiento. Mantenga este aparato lejos del alcance los niños y los animales. Su pequeño tamaño y la pila interna suponen un riesgo de atragantamiento o ahogamiento. EL no atender a estas precauciones puede dar lugar a un accidente grave o incluso la muerte.

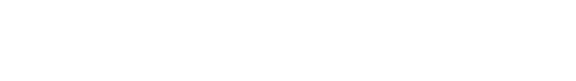

⚠️ 重要安全信息

- 阅读这些说明。
- 保留这些说明。
- 注意所有警告。
- 遵守所有说明。
- 请勿在水旁使用本设备。
- 仅使用干布清洁。
- 将电池丢入火或热烤箱中,或机械性粉碎或切割电池,可能导致爆炸。
- 将电池留在极高的温度周围环境中,可能导致爆炸或易燃液体或气体泄漏。
- 将电池置于极低气压中,可能导致爆炸或易燃液体或气体泄漏。
- 不要拆解或修改本产品。
- 不要更换电池,它可能会使保护失效。
- 请将本产品存放在清洁干燥的环境中。
- 最少每月充电一次。
- 充电时不要无人看管。
- 警告!** 窒息和吞咽危险。让产品安全地远离儿童和宠物。小尺寸和内部电池存在窒息和吞咽危险。不遵守指示可能导致永久性伤害或死亡。

⚠️ Consigne de sécurité importantes

- Lisez ces instructions.
- Conservez ces instructions.
- Tenez compte de tous les avertissements.
- Suivez toutes les instructions.
- N'utilisez pas cet appareil à proximité de l'eau.
- Nettoyez uniquement avec un chiffon sec.
- Placer la batterie dans des flammes ou un four chaud, ou tenter de l'écraser ou de la couper mécaniquement peut produire une explosion.
- Laisser la batterie dans un environnement aux températures extrêmement élevées peut produire une explosion ou une fuite de liquide ou gaz inflammable.
- Une batterie soumise à une pression de l'air très faible peut causer une explosion ou la fuite de liquide ou gaz inflammable
- Ne démontez pas et ne modifiez pas cet appareil.
- Ne remplacez pas la batterie, elle peut contourner un dispositif de protection.
- Conservez cet appareil dans un endroit propre et sec.
- Rechargez au moins une fois par mois.
- Ne laissez pas l'appareil sans surveillance durant la charge.
- AVERTISSEMENT !** Risque d'ingestion et d'étouffement. Conservez ce produit hors de portée des enfants et des animaux de compagnie. Les petites pièces et les piles peuvent être avalées et provoquer la suffocation. Le non-respect de ces instructions peut entrainer des blessures permanentes et même la mort.

⚠️ Wichtige Sicherheitshinweise

- Lesen Sie diese Anleitungen.
- Bewahren Sie diese Anleitungen auf.
- Beachten Sie alle Warnungen.
- Befolgen Sie alle Anweisungen.
- Verwenden Sie dieses Gerät nicht in der Nähe von Wasser.
- Reinigen Sie das Gerät nur mit einem trockenen Tuch.
- Das Entsorgen von Batterien/Akkus im Feuer oder einem heißen Ofen oder das mechanische Zerkleinern oder Zerschneiden der Batterie kann zu einer Explosion führen.
- Wenn Sie eine Batterie in einer Umgebung mit extrem hohen Temperaturen lagern, kann dies zu einer Explosion oder zum Austreten von brennbaren Flüssigkeiten oder Gasen führen.
- Wenn eine Batterie extrem niedrigem Luftdruck ausgesetzt ist, kann dies zu einer Explosion oder zum Austritt von brennbaren Flüssigkeiten oder Gasen führen.
- Demontieren oder modifizieren Sie dieses Produkt nicht.
- Tauschen Sie die Batterie nicht aus. Dies könnte eine Sicherungsfunktion außer Kraft setzen.
- Bitte lagern Sie dieses Produkt in einer sauberen und trockenen Umgebung.
- Laden Sie die Batterie einmal im Monat (mindestens).
- Lassen Sie die Batterie während des Ladens nicht unbeaufsichtigt.
- WARNUNG!** Gefahr des Erstickens und Verschluckens. Bewahren Sie das Produkt sicher außerhalb der Reichweite von Kindern und Haustieren auf. Die geringe Größe und die interne Batterie stellen eine Erstickungs- und Verschluckungsgefahr dar. Die Nichtbeachtung der Anweisungen kann zu dauerhaften Schäden oder zum Tod führen.

⚠️ Informações de segurança importantes

- Leia estas instruções.
- Guarde estas instruções.
- Preste atenção a todos os avisos.
- Siga todas as instruções.
- Não use esse aparelho próximo à água.
- Limpe apenas com pano seco.
- O descarte da bateria no fogo ou forno quente, esmagamento ou corte mecânico de uma bateria, podem causar uma explosão.
- Deixar a bateria em um ambiente com temperatura extremamente alta pode causar uma explosão ou vazamento de gás ou líquido inflamável.
- Deixar a bateria em um ambiente com pressão extremamente baixa pode causar uma explosão ou vazamento de gás ou líquido inflamável.
- Não desmonte nem modifique esse produto.
- Não substitua uma bateria. Isso pode prejudicar uma salvaguarda.
- Por favor, guarde esse produto em um ambiente limpo e seco.
- Carregue uma vez por mês (mínimo).
- Não deixe o dispositivo sem supervisão enquanto o carrega.
- ADVERTÊNCIA!** Perigo de asfixia e de engolir. Mantenha o produto em segurança fora do alcance de crianças e animais de estimação. O tamanho pequeno e a bateria interna representam perigo de asfixia e de ser engolido. O não cumprimento das instruções pode levar a danos permanentes ou morte.

⚠️ Importanti istruzioni di sicurezza

- Leggete queste istruzioni.
- Conservate queste istruzioni.
- Rispettate tutti gli avvertimenti.
- Seguite tutte le istruzioni.
- Non utilizzate questo dispositivo vicino l'acqua.
- Pulite solamente con un panno asciutto.
- Lo smaltimento di una batteria nel fuoco o in un forno caldo, oppure lo schiacciamento o il taglio meccanico di una batteria, può provocare un'esplosione
- Lasciare una batteria in un ambiente a temperatura estremamente elevata può provocare un'esplosione o la perdita di liquido o gas infiammabile.
- Una batteria sottoposta a una pressione dell'aria estremamente bassa può provocare un'esplosione o la perdita di liquido o gas infiammabile.
- Non smontate né modificate questo prodotto.
- Non sostituite la batteria. Ciò può disattivare la protezione.
- Conservate questo prodotto in un ambiente pulito e asciutto.
- Ricaricate (almeno) una volta al mese.
- Non lasciare incustoditi durante la ricarica.
- AVVERTENZA!** Rischio di soffocamento e ingestione. Tenere il prodotto in modo sicuro fuori dalla portata dei bambini e degli animali domestici. Le dimensioni ridotte e la batteria interna comportano il rischio di soffocamento e ingestione. La mancata osservanza delle istruzioni può causare danni permanenti o morte.



Ⓔ Accessories List

- T-BUDS x 1 pair
- Charging case
- Charging cable, USB
- This quick start guide
- Silicone earplugs in 3 sizes

Features

- High-fidelity true wireless stereo earbuds provide wide frequency response (20 Hz - 20 kHz), delivering full bass and detailed highs
- Bluetooth® 5.0 true wireless technology for exceptional sound quality with up to 10 m (33 ft) of wireless freedom
- State-of-the-art, active noise cancellation with transparent mode feature enables awareness of surroundings while enjoying your music
- Splash-proof construction (IPX4) is ideal for sports, work out and any outdoor activity that requires pure listening pleasure
- Secure in-ear design ensures stability and comfort
- Seamless phone, voice commands, volume and music via touch control
- Up to 4 hours of battery life that can be extended up to 16 hours with the integrated battery charging case
- USB charging cable included
- Includes replacement silicon buds and optional bud sizes for custom fitting

Getting Started

Before use, please read this quick start guide carefully and keep it in a safe place. Please fully charge the earbuds before use. Do not leave unattended while charging. Please regularly charge the earbuds if you do not use them for a long time (more than 3 months). Please use the supplied charger cable only.

The earbuds are in the charging state (non-working state) when they are inside the charging case.

The charging case lid slides backwards to access the earbuds. Carefully fit the earbuds in your ears, and you will hear a voice prompt for pairing (as the earbuds are in BT discover mode).

LED indication on earbuds:	
Charging	Red
Fully charged	Red light will turn off
Pairing mode	Red and Blue lights flashing alternately
BT connected	Blue
Charging case	
USB Type C charging port at the rear	
The 3 case LEDs show the status of the charging case power remaining	

⚠️ Belangrijke veiligheidsinformatie

- Lees deze instructies.
- Bewaar deze instructies.
- Let op alle waarschuwingen.
- Volg alle instructies op.
- Gebruik dit apparaat niet in de buurt van water.
- Alleen reinigen met een droge doek.
- Verwijdering van een accu in vuur, hete oven of mechanisch samenpersen of openzagen van een accu kan leiden tot een explosie.
- Als een accu in een omgeving met extreem hoge temperatuur komt, kan er een explosie ontstaan of kan er ontvlambare vloeistof of gas lekken.
- Een accu in te lage luchtdruk kan leiden tot een explosie of lekkage van ontvlambare vloeistof of gas.
- Dit product niet demonteren of aanpassen.
- Vervang een accu niet. Dit kan een veiligheidsvoorziening uitschakelen.
- Bewaar dit product in een schone en droge omgeving.
- Laad één keer per maand op (het minimum).
- Tijdens het opladen niet onbeheerd achterlaten.
- WAARSCHUWING!** Gevaar voor inslikken en stikken. Houd het product veilig buiten bereik van kinderen en huisdieren. De kleine omvang en de interne accu vormen een gevaar voor inslikken en stikken. Het niet opvolgen van instructies kan leiden tot permanente schade of de dood.

⚠️ Viktig säkerhetsinformation

- Läs dessa anvisningar.
- Behåll dessa anvisningar.
- Beakta alla varningar.
- Följ alla anvisningar.
- Använd inte denna anordning nära vatten.
- Rengör endast med torr trasa.
- Om ett batteri läggs i en eld eller i en varm ugn, eller om ett batteri mekaniskt krossas eller skärs, kan det resultera i en explosion.
- Om ett batteri lämnas i en omgivande miljö med extrem hög temperatur kan det resultera i en explosion eller läckage av brandfarlig vätska eller gas.
- Om ett batteri utsätts för ett extremt lågt lufttryck kan det resultera i en explosion eller läckage av brandfarlig vätska eller gas.
- Ta inte isär och modifiera inte denna produkt.
- Byt inte ut ett batteri. Det kan motverka en säkerhetsåtgärd.
- Förvara denna produkt i en ren och torr miljö.
- Ladda den (minst) en gång per månad.
- Lämnna inte utan uppsikt under laddning.
- VARNING!** Fara för sväljning och kvävning. Håll produkten utom räckhåll för barn och husdjur. Det lilla formatet och det interna batteriet utgör en fara för kvävning och sväljning. Underlåtenhet att följa anvisningar kan leda till permanent skada eller dödsfall.



General Operation

Power On / Off	
Power On	Press and hold for 2 seconds
Power Off	Press and hold for 4 seconds
Music Controls	
Play the Track	Tap once on any earbud
Pause the Track	Tap once on any earbud
Next Track	Tap twice on RIGHT earbud
Previous Track	Tap twice on LEFT earbud
Phone Call Controls	
Answer incoming call	Tap once on any earbud
Refuse incoming call	Press and hold for 2 seconds
End the call	Tap once on any earbud
Voice Assist Control	
Activate Voice Assist	Tap 2 times on any earbud
Pairing	
Clear Pairing	Tap 4 times on any earbud
ANC Control	
ANC ON	Press and hold for 2 seconds
ANC OFF	Press and hold for 2 seconds
Transparent Mode	Press and hold for 2 seconds

Using both earbuds, or a single earbud

- Make sure both earbuds are off, and your phone or other device's Bluetooth is turned off.
- CAUTION:** Turn down the volume of your phone or other device. This is important to help reduce the possibility of hearing damage.
- Touch and hold both earbud buttons for 3 seconds, to turn on and enter pairing mode (the earbud's LED will flash in red and blue).
- Turn on the Bluetooth mode on your phone or device, and search for the earbuds on your screen. Click and connect it. When connected successfully, the LEDs on both earbuds will turn blue.

Troubleshooting tips:

- If your phone cannot find the earbuds, please check that the earbuds are in pairing mode. If the earbuds are not paired for a long time, please turn on the earbuds to pair again. Sometimes it is better to reset the earbuds and the bluetooth function of the phone.
- If it is not possible to talk or listen to music while connected successfully: You might need to choose Bluetooth "Mobile Audio" or "Media Audio" when using an Android system, or please choose Bluetooth on call interface.
- If your phone or device is paired/connected with the earbuds but there is no sound: Try removing the earbuds as a Bluetooth device and then pair with your phone or device a second time.

Driver unit	10 mm
Impedance	32 Ohm
Frequency response	20 Hz - 20 kHz
SPL	96 dB @1kHz
Rated / peak power	3 mW (5 mW peak)
Bluetooth version	V 5.0
Bluetooth range	up to 10m (33ft) line of sight
CODEC support	AAC, SBC
Microphone sensitivity	(- 42 dB ± 3 dB) @1kHz, 0dB=1V/Pa
Battery type	Rechargeable Lithium battery
Working time (case)	Up to 4 hours (+ 12 hours via charging case)
Standby time	150 hours
Charging time	1 hour via USB 5V

Warning! To prevent possible hearing damage, do not listen at high volume levels for long periods. As a guide to setting the volume level, check that you can still hear your own voice, when speaking normally while listening with the headphones.

Warning! Batteries (battery pack or batteries installed) shall not be exposed to excessive heat such as sunshine, fire or the like.

Warning! Batteries (battery pack or batteries installed) shall not be exposed to excessive heat such as sunshine, fire or the like.

Warning! To prevent possible hearing damage, do not listen at high volume levels for long periods. As a guide to setting the volume level, check that you can still hear your own voice, when speaking normally while listening with the headphones.

Warning! Batteries (battery pack or batteries installed) shall not be exposed to excessive heat such as sunshine, fire or the like.

Warning! To prevent possible hearing damage, do not listen at high volume levels for long periods. As a guide to setting the volume level, check that you can still hear your own voice, when speaking normally while listening with the headphones.

Warning! Batteries (battery pack or batteries installed) shall not be exposed to excessive heat such as sunshine, fire or the like.

Warning! To prevent possible hearing damage, do not listen at high volume levels for long periods. As a guide to setting the volume level, check that you can still hear your own voice, when speaking normally while listening with the headphones.

Warning! Batteries (battery pack or batteries installed) shall not be exposed to excessive heat such as sunshine, fire or the like.

Warning! To prevent possible hearing damage, do not listen at high volume levels for long periods. As a guide to setting the volume level, check that you can still hear your own voice, when speaking normally while listening with the headphones.

Warning! Batteries (battery pack or batteries installed) shall not be exposed to excessive heat such as sunshine, fire or the like.

Warning! To prevent possible hearing damage, do not listen at high volume levels for long periods. As a guide to setting the volume level, check that you can still hear your own voice, when speaking normally while listening with the headphones.

Warning! Batteries (battery pack or batteries installed) shall not be exposed to excessive heat such as sunshine, fire or the like.

Warning! To prevent possible hearing damage, do not listen at high volume levels for long periods. As a guide to setting the volume level, check that you can still hear your own voice, when speaking normally while listening with the headphones.

Warning! Batteries (battery pack or batteries installed) shall not be exposed to excessive heat such as sunshine, fire or the like.

Warning! To prevent possible hearing damage, do not listen at high volume levels for long periods. As a guide to setting the volume level, check that you can still hear your own voice, when speaking normally while listening with the headphones.

Warning! Batteries (battery pack or batteries installed) shall not be exposed to excessive heat such as sunshine, fire or the like.

Warning! To prevent possible hearing damage, do not listen at high volume levels for long periods. As a guide to setting the volume level, check that you can still hear your own voice, when speaking normally while listening with the headphones.

Warning! Batteries (battery pack or batteries installed) shall not be exposed to excessive heat such as sunshine, fire or the like.

Warning! To prevent possible hearing damage, do not listen at high volume levels for long periods. As a guide to setting the volume level, check that you can still hear your own voice, when speaking normally while listening with the headphones.

Warning! Batteries (battery pack or batteries installed) shall not be exposed to excessive heat such as sunshine, fire or the like.

Warning! To prevent possible hearing damage, do not listen at high volume levels for long periods. As a guide to setting the volume level, check that you can still hear your own voice, when speaking normally while listening with the headphones.

Warning! Batteries (battery pack or batteries installed) shall not be exposed to excessive heat such as sunshine, fire or the like.

Warning! To prevent possible hearing damage, do not listen at high volume levels for long periods. As a guide to setting the volume level, check that you can still hear your own voice, when speaking normally while listening with the headphones.

Warning! Batteries (battery pack or batteries installed) shall not be exposed to excessive heat such as sunshine, fire or the like.

Warning! To prevent possible hearing damage, do not listen at high volume levels for long periods. As a guide to setting the volume level, check that you can still hear your own voice, when speaking normally while listening with the headphones.

Warning! Batteries (battery pack or batteries installed) shall not be exposed to excessive heat such as sunshine, fire or the like.

Warning! To prevent possible hearing damage, do not listen at high volume levels for long periods. As a guide to setting the volume level, check that you can still hear your own voice, when speaking normally while listening with the headphones.

Warning! Batteries (battery pack or batteries installed) shall not be exposed to excessive heat such as sunshine, fire or the like.

Warning! To prevent possible hearing damage, do not listen at high volume levels for long periods. As a guide to setting the volume level, check that you can still hear your own voice, when speaking normally while listening with the headphones.

Warning! Batteries (battery pack or batteries installed) shall not be exposed to excessive heat such as sunshine, fire or the like.

Other important information

1. Register online. Please register your new Music Tribe equipment right after you purchase it by visiting musictribe.com. Registering your purchase using our simple online form helps us to process your repair claims more quickly and efficiently. Also, read the terms and conditions of our warranty, if applicable.

2. Malfunction. Should your Music Tribe Authorized Reseller not be located in your vicinity, you may contact the Music Tribe Authorized Fulfiller for your country listed under "Support" at musictribe.com. Should your country not be listed, please check if your problem can be dealt with by our "Online Support" which may also be found under "Support" at musictribe.com. Alternatively, please submit an online warranty claim at musictribe.com BEFORE returning the product.

Otra información importante

1. Registro online. Le recomendamos que registre su nuevo aparato Music Tribe justo después de su compra accediendo a la página web musictribe.com. El registro de su compra a través de nuestro sencillo sistema online nos ayudará a resolver cualquier incidencia que se presente a la mayor brevedad posible. Además, aproveche para leer los términos y condiciones de nuestra garantía, si es aplicable en su caso.

2. Averías. En el caso de que no exista un distribuidor Music Tribe en las inmediaciones, puede ponerse en contacto con el distribuidor Music Tribe de su país, que encontrará dentro del apartado "Support" de nuestra página web musictribe.com. En caso de que su país no aparezca en ese listado, acceda a la sección "Online Support" (que también encontrará dentro del apartado "Support" de nuestra página web) y compruebe si su problema aparece descrito y solucionado allí. De forma alternativa, envíenos a través de la página web una solicitud online de soporte en periodo de garantía ANTES de devolvemos el aparato.

Autres informations importantes

1. Enregistrez-vous en ligne. Prenez le temps d’enregistrer votre produit Music Tribe aussi vite que possible sur le site Internet musictribe.com. Le fait d’enregistrer le produit en ligne nous permet de gérer les réparations plus rapidement et plus efficacement. Prenez également le temps de lire les termes et conditions de notre garantie.

2. Dysfonctionnement. Si vous n’avez pas de revendeur Music Tribe près de chez vous, contactez le distributeur Music Tribe de votre pays : consultez la liste des distributeurs de votre pays dans la page "Support" de notre site Internet musictribe.com. Si votre pays n’est pas dans la liste, essayez de résoudre votre problème avec notre "aide en ligne" que vous trouverez également dans la section "Support" du site musictribe.com. Vous pouvez également nous faire parvenir directement votre demande de réparation sous garantie par Internet sur le site musictribe.com AVANT de nous renvoyer le produit.

Andere wichtige Informationen

1. Online registrieren. Bitte registrieren Sie Ihr neues Music Tribe-Gerät direkt nach dem Kauf auf der Website musictribe.com. Wenn Sie Ihren Kauf mit unserem einfachen online Formular registrieren, können wir Ihre Reparaturansprüche schneller und effizienter bearbeiten. Lesen Sie bitte auch unsere Garantiebedingungen, falls zutreffend.

2. Funktionsfehler. Sollte sich kein Music Tribe Händler in Ihrer Nähe befinden, können Sie den Music Tribe Vertrieb Ihres Landes kontaktieren, der auf musictribe.com unter „Support“ aufgeführt ist. Sollte Ihr Land nicht aufgelistet sein, prüfen Sie bitte, ob Ihr Problem von unserem „Online Support“ gelöst werden kann, den Sie ebenfalls auf musictribe.com unter „Support“ finden. Alternativ reichen Sie bitte Ihren Garantieanspruch online auf musictribe.com ein, BEVOR Sie das Produkt zurücksenden.

Warning! To prevent possible hearing damage, do not listen at high volume levels for long periods. As a guide to setting the volume level, check that you can still hear your own voice, when speaking normally while listening with the headphones.

Warning! Batteries (battery pack or batteries installed) shall not be exposed to excessive heat such as sunshine, fire or the like.

Warning! To prevent possible hearing damage, do not listen at high volume levels for long periods. As a guide to setting the volume level, check that you can still hear your own voice, when speaking normally while listening with the headphones.

Warning! Batteries (battery pack or batteries installed) shall not be exposed to excessive heat such as sunshine, fire or the like.

Warning! To prevent possible hearing damage, do not listen at high volume levels for long periods. As a guide to setting the volume level, check that you can still hear your own voice, when speaking normally while listening with the headphones.

Warning! Batteries (battery pack or batteries installed) shall not be exposed to excessive heat such as sunshine, fire or the like.

Warning! To prevent possible hearing damage, do not listen at high volume levels for long periods. As a guide to setting the volume level, check that you can still hear your own voice, when speaking normally while listening with the headphones.

Warning! Batteries (battery pack or batteries installed) shall not be exposed to excessive heat such as sunshine, fire or the like.

Warning! To prevent possible hearing damage, do not listen at high volume levels for long periods. As a guide to setting the volume level, check that you can still hear your own voice, when speaking normally while listening with the headphones.

Warning! Batteries (battery pack or batteries installed) shall not be exposed to excessive heat such as sunshine, fire or the like.

Warning! To prevent possible hearing damage, do not listen at high volume levels for long periods. As a guide to setting the volume level, check that you can still hear your own voice, when speaking normally while listening with the headphones.

Warning! Batteries (battery pack or batteries installed) shall not be exposed to excessive heat such as sunshine, fire or the like.

Warning! To prevent possible hearing damage, do not listen at high volume levels for long periods. As a guide to setting the volume level, check that you can still hear your own voice, when speaking normally while listening with the headphones.

Warning! Batteries (battery pack or batteries installed) shall not be exposed to excessive heat such as sunshine, fire or the like.

Warning! To prevent possible hearing damage, do not listen at high volume levels for long periods. As a guide to setting the volume level, check that you can still hear your own voice, when speaking normally while listening with the headphones.

Warning! Batteries (battery pack or batteries installed) shall not be exposed to excessive heat such as sunshine, fire or the like.

Warning! To prevent possible hearing damage, do not listen at high volume levels for long periods. As a guide to setting the volume level, check that you can still hear your own voice, when speaking normally while listening with the headphones.

Warning! Batteries (battery pack or batteries installed) shall not be exposed to excessive heat such as sunshine, fire or the like.

Warning! To prevent possible hearing damage, do not listen at high volume levels for long periods. As a guide to setting the volume level, check that you can still hear your own voice, when speaking normally while listening with the headphones.

Warning! Batteries (battery pack or batteries installed) shall not be exposed to excessive heat such as sunshine, fire or the like.

Outras informações importantes

1. Registre-se online. Por favor, registre seu novo equipamento Music Tribe logo após a compra visitando o site musictribe.com. Registrar sua compra usando nosso simples formulário online nos ajuda a processar seus pedidos de reparos com maior rapidez e eficiência. Além disso, leia nossos termos e condições de garantia, caso seja necessário.

2. Funcionamento Defeituoso. Caso seu fomecedor Music Tribe não esteja localizado nas proximidades, você pode contatar um distribuidor Music Tribe para o seu país listado abaixo de "Suporte" em musictribe.com. Se seu país não estiver na lista, favor checar se seu problema pode ser resolvido com o nosso "Suporte Online" que também pode ser achado abaixo de "Suporte" em musictribe.com. Alternativamente, favor enviar uma solicitação de garantia online em musictribe.com ANTES da devolução do produto.

Altre informazioni importanti

1. Registratevi online. Vi invitiamo a registrare il nuovo apparecchio Music Tribe subito dopo averlo acquistato visitando musictribe.com. La registrazione dell'acquisto tramite il nostro semplice modulo online ci consente di elaborare le richieste di riparazione in modo più rapido ed efficiente. Leggete anche i termini e le condizioni della nostra garanzia, qualora applicabile.

2. Malfunzionamento. Nel caso in cui il rivenditore autorizzato Music Tribe non si trovi nelle vostre vicinanze, potete contattare il Music Tribe Authorized Fulfiller per il vostro paese, elencato in "Support" @ musictribe.com. Se la vostra nazione non è elencata, controllate se il problema può essere risolto tramite il nostro "Online Support" che può anche essere trovato sotto "Support" @ musictribe.com. In alternativa, inviate una richiesta di garanzia online su musictribe.com PRIMA di restituire il prodotto.

Andere belangrijke informatie

1. Registreer online. Registreer uw nieuwe Music Tribe-apparatuur direct nadat u deze hebt gekocht door naar musictribe.com te gaan. Door uw aankoop te registreren via ons eenvoudige online formulier, kunnen wij uw reparatieclaims sneller en efficiënter verwerken. Lees ook de voorwaarden van onze garantie, indien van toepassing.

2. Storing. Mocht uw door Music Tribe geautoriseerde wederverkoper niet bij u in de buurt zijn gevestigd, dan kunt u contact opnemen met de door Music Tribe Authorized Fulfiller voor uw land vermeld onder "Support" op musictribe.com. Als uw land niet in de lijst staat, controleer dan of uw probleem kan worden opgelost door onze "Online Support", die u ook kunt vinden onder "Support" op musictribe.com. U kunt ook een online garantieclaim indienen op musictribe.com VOORDAT u het product retourneert.

Annan viktig information

1. Registrera online. Registrera din nya Music Tribe-utrustning direkt efter att du köpt den genom att besöka musictribe.com. Att registrera ditt köp med vårt enkla onlineformulär hjälper oss att behandla dina reparationsanspråk snabbare och mer effektivt. Läs också villkoren i vår garanti, om tillämpligt.

2. Fel. Om din Music Tribe- auktoriserade återförsäljare inte finns i din närhet kan du kontakta Music Tribe Authorized Fulfiller för ditt land listat under "Support" på musictribe.com. Om ditt land inte är listat, kontrollera om ditt problem kan hanteras av vår "Onlinesupport" som också finns under "Support" på musictribe.com. Alternativt kan du skicka in ett online-garantianspråk på musictribe.com INNAN du returnerar produkten.

Warning! To prevent possible hearing damage, do not listen at high volume levels for long periods. As a guide to setting the volume level, check that you can still hear your own voice, when speaking normally while listening with the headphones.

Warning! Batteries (battery pack or batteries installed) shall not be exposed to excessive heat such as sunshine, fire or the like.

Warning! To prevent possible hearing damage, do not listen at high volume levels for long periods. As a guide to setting the volume level, check that you can still hear your own voice, when speaking normally while listening with the headphones.

Warning! Batteries (battery pack or batteries installed) shall not be exposed to excessive heat such as sunshine, fire or the like.

Warning! To prevent possible hearing damage, do not listen at high volume levels for long periods. As a guide to setting the volume level, check that you can still hear your own voice, when speaking normally while listening with the headphones.

Warning! Batteries (battery pack or batteries installed) shall not be exposed to excessive heat such as sunshine, fire or the like.

Warning! To prevent possible hearing damage, do not listen at high volume levels for long periods. As a guide to setting the volume level, check that you can still hear your own voice, when speaking normally while listening with the headphones.

Warning! Batteries (battery pack or batteries installed) shall not be exposed to excessive heat such as sunshine, fire or the like.

Warning! To prevent possible hearing damage, do not listen at high volume levels for long periods. As a guide to setting the volume level, check that you can still hear your own voice, when speaking normally while listening with the headphones.

Warning! Batteries (battery pack or batteries installed) shall not be exposed to excessive heat such as sunshine, fire or the like.

Warning! To prevent possible hearing damage, do not listen at high volume levels for long periods. As a guide to setting the volume level, check that you can still hear your own voice, when speaking normally while listening with the headphones.

Warning! Batteries (battery pack or batteries installed) shall not be exposed to excessive heat such as sunshine, fire or the like.

Warning! To prevent possible hearing damage, do not listen at high volume levels for long periods. As a guide to setting the volume level, check that you can still hear your own voice, when speaking normally while listening with the headphones.

Warning! Batteries (battery pack or batteries installed) shall not be exposed to excessive heat such as sunshine, fire or the like.

Warning! To prevent possible hearing damage, do not listen at high volume levels for long periods. As a guide to setting the volume level, check that you can still hear your own voice, when speaking normally while listening with the headphones.

Warning! Batteries (battery pack or batteries installed) shall not be exposed to excessive heat such as sunshine, fire or the like.

Warning! To prevent possible hearing damage, do not listen at high volume levels for long periods. As a guide to setting the volume level, check that you can still hear your own voice, when speaking normally while listening with the headphones.

Warning! Batteries (battery pack or batteries installed) shall not be exposed to excessive heat such as sunshine, fire or the like.

Warning! To prevent possible hearing damage, do not listen at high volume levels for long periods. As a guide to setting the volume level, check that you can still hear your own voice, when speaking normally while listening with the headphones.

Warning! Batteries (battery pack or batteries installed) shall not be exposed to excessive heat such as sunshine, fire or the like.

Warning! To prevent possible hearing damage, do not listen at high volume levels for long periods. As a guide to setting the volume level, check that you can still hear your own voice, when speaking normally while listening with the headphones.

Inne ważne informacje

1. Zarejestrować online. Zarejestruj swój nowy sprzęt Music Tribe zaraz po zakupie na stronie musictribe.com. Zarejestrowanie zakupu za pomocą naszego prostego formularza online pomaga nam szybciej i efektywniej rozpatrywać roszczenia dotyczące naprawy. Przeczytaj również warunki naszej gwarancji, jeśli dotyczy.

2. Awaria. Jeśli Twój autoryzowany sprzedawca Music Tribe nie znajduje się w pobliżu, możesz skontaktować się z autoryzowanym dostawcą Music Tribe dla swojego kraju, wymienionym w sekcji „Wsparcie” na stronie musictribe.com. Jeśli Twójego kraju nie ma na liście, sprawdź, czy Twój problem może zostać rozwiązany przez nasze „Wsparcie online”, które można również znaleźć w sekcji „Wsparcie” na stronie musictribe.com. Altematywnie, przeslij zgłoszenie gwarancyjne online na musictribe.com PRZED zwrotem produktu.

その他の重要な情報

1. ヒューズの格納部 / 電圧の選択: ユニットをパワーソケットに接続する前に、各モデルに対応した正しい主電源を使用していることを確認してください。ユニットによっては、230Vと120Vの2つの違うポジションを切り替えて使う、ヒューズの格納部を備えているものがあります。正しくない値のヒューズは、絶対に適切な値のヒューズに交換されている必要があります。

2. 故障: Music Tribe ディーラーがお客様のお近くにないときは、musictribe.com の "Support" 内に列記されている、お客様の国の Music Tribe ディストリビューターにコンタクトすることができます。お客様の国がリストにない場合は、同じ musictribe.com の "Support" 内にある "Online Support" でお客様の問題が処理できないか、チェックしてみてください。あるいは、商品を返送する前に、musictribe.com で、オンラインの保証請求を要請してください。

Warning! To prevent possible hearing damage, do not listen at high volume levels for long periods. As a guide to setting the volume level, check that you can still hear your own voice, when speaking normally while listening with the headphones.

Warning! Batteries (battery pack or batteries installed) shall not be exposed to excessive heat such as sunshine, fire or the like.

Warning! To prevent possible hearing damage, do not listen at high volume levels for long periods. As a guide to setting the volume level, check that you can still hear your own voice, when speaking normally while listening with the headphones.

Warning! Batteries (battery pack or batteries installed) shall not be exposed to excessive heat such as sunshine, fire or the like.

Warning! To prevent possible hearing damage, do not listen at high volume levels for long periods. As a guide to setting the volume level, check that you can still hear your own voice, when speaking normally while listening with the headphones.

Warning! Batteries (battery pack or batteries installed) shall not be exposed to excessive heat such as sunshine, fire or the like.

Warning! To prevent possible hearing damage, do not listen at high volume levels for long periods. As a guide to setting the volume level, check that you can still hear your own voice, when speaking normally while listening with the headphones.

Warning! Batteries (battery pack or batteries installed) shall not be exposed to excessive heat such as sunshine, fire or the like.

Warning! To prevent possible hearing damage, do not listen at high volume levels for long periods. As a guide to setting the volume level, check that you can still hear your own voice, when speaking normally while listening with the headphones.

Warning! Batteries (battery pack or batteries installed) shall not be exposed to excessive heat such as sunshine, fire or the like.

Warning! To prevent possible hearing damage, do not listen at high volume levels for long periods. As a guide to setting the volume level, check that you can still hear your own voice, when speaking normally while listening with the headphones.

Warning! Batteries (battery pack or batteries installed) shall not be exposed to excessive heat such as sunshine, fire or the like.

Warning! To prevent possible hearing damage, do not listen at high volume levels for long periods. As a guide to setting the volume level, check that you can still hear your own voice, when speaking normally while listening with the headphones.

Warning! Batteries (battery pack or batteries installed) shall not be exposed to excessive heat such as sunshine, fire or the like.

Warning! To prevent possible hearing damage, do not listen at high volume levels for long periods. As a guide to setting the volume level, check that you can still hear your own voice, when speaking normally while listening with the headphones.

Warning! Batteries (battery pack or batteries installed) shall not be exposed to excessive heat such as sunshine, fire or the like.

Warning! To prevent possible hearing damage, do not listen at high volume levels for long periods. As a guide to setting the volume level, check that you can still hear your own voice, when speaking normally while listening with the headphones.

Warning! Batteries (battery pack or batteries installed) shall not be exposed to excessive heat such as sunshine, fire or the like.

Warning! To prevent possible hearing damage, do not listen at high volume levels for long periods. As a guide to setting the volume level, check that you can still hear your own voice, when speaking normally while listening with the headphones.

Warning! Batteries (battery pack or batteries installed) shall not be exposed to excessive heat such as sunshine, fire or the like.

Warning! To prevent possible hearing damage, do not listen at high volume levels for long periods. As a guide to setting the volume level, check that you can still hear your own voice, when speaking normally while listening with the headphones.

Warning! Batteries (battery pack or batteries installed) shall not be exposed to excessive heat such as sunshine, fire or the like.

Warning! To prevent possible hearing damage, do not listen at high volume levels for long periods. As a guide to setting the volume level, check that you can still hear your own voice, when speaking normally while listening with the headphones.

Warning! Batteries (battery pack or batteries installed) shall not be exposed to excessive heat such as sunshine, fire or the like.

Warning! To prevent possible hearing damage, do not listen at high volume levels for long periods. As a guide to setting the volume level, check that you can still hear your own voice, when speaking normally while listening with the headphones.

Warning! Batteries (battery pack or batteries installed) shall not be exposed to excessive heat such as sunshine, fire or the like.

Warning! To prevent possible hearing damage, do not listen at high volume levels for long periods. As a guide to setting the volume level, check that you can still hear your own voice, when speaking normally while listening with the headphones.

Warning! Batteries (battery pack or batteries installed) shall not be exposed to excessive heat such as sunshine, fire or the like.

Warning! To prevent possible hearing damage, do not listen at high volume levels for long periods. As a guide to setting the volume level, check that you can still hear your own voice, when speaking normally while listening with the headphones.

Warning! To prevent possible hearing damage, do not listen at high volume levels for long periods. As a guide to setting the volume level, check that you can still hear your own voice, when speaking normally while listening with the headphones.

Warning! Batteries (battery pack or batteries installed) shall not be exposed to excessive heat such as sunshine, fire or the like.

Warning! To prevent possible hearing damage, do not listen at high volume levels for long periods. As a guide to setting the volume level, check that you can still hear your own voice, when speaking normally while listening with the headphones.

Warning! Batteries (battery pack or batteries installed) shall not be exposed to excessive heat such as sunshine, fire or the like.

Warning! To prevent possible hearing damage, do not listen at high volume levels for long periods. As a guide to setting the volume level, check that you can still hear your own voice, when speaking normally while listening with the headphones.

Warning! Batteries (battery pack or batteries installed) shall not be exposed to excessive heat such as sunshine, fire or the like.

Warning! To prevent possible hearing damage, do not listen at high volume levels for long periods. As a guide to setting the volume level, check that you can still hear your own voice, when speaking normally while listening with the headphones.

Warning! Batteries (battery pack or batteries installed) shall not be exposed to excessive heat such as sunshine, fire or the like.

Warning! To prevent possible hearing damage, do not listen at high volume levels for long periods. As a guide to setting the volume level, check that you can still hear your own voice, when speaking normally while listening with the headphones.

Warning! Batteries (battery pack or batteries installed) shall not be exposed to excessive heat such as sunshine, fire or the like.

Warning! To prevent possible hearing damage, do not listen at high volume levels for long periods. As a guide to setting the volume level, check that you can still hear your own voice, when speaking normally while listening with the headphones.

Warning! Batteries (battery pack or batteries installed) shall not be exposed to excessive heat such as sunshine, fire or the like.

Warning! To prevent possible hearing damage, do not listen at high volume levels for long periods. As a guide to setting the volume level, check that you can still hear your own voice, when speaking normally while listening with the headphones.

Warning! Batteries (battery pack or batteries installed) shall not be exposed to excessive heat such as sunshine, fire or the like.

Warning! To prevent possible hearing damage, do not listen at high volume levels for long periods. As a guide to setting the volume level, check that you can still hear your own voice, when speaking normally while listening with the headphones.

Warning! Batteries (battery pack or batteries installed) shall not be exposed to excessive heat such as sunshine, fire or the like.

Warning! To prevent possible hearing damage, do not listen at high volume levels for long periods. As a guide to setting the volume level, check that you can still hear your own voice, when speaking normally while listening with the headphones.

Warning! Batteries (battery pack or batteries installed) shall not be exposed to excessive heat such as sunshine, fire or the like.

Warning! To prevent possible hearing damage, do not listen at high volume levels for long periods. As a guide to setting the volume level, check that you can still hear your own voice, when speaking normally while listening with the headphones.

Warning! Batteries (battery pack or batteries installed) shall not be exposed to excessive heat such as sunshine, fire or the like.

Warning! To prevent possible hearing damage, do not listen at high volume levels for long periods. As a guide to setting the volume level, check that you can still hear your own voice, when speaking normally while listening with the headphones.

Warning! Batteries (battery pack or batteries installed) shall not be exposed to excessive heat such as sunshine, fire or the like.

Warning! To prevent possible hearing damage, do not listen at high volume levels for long periods. As a guide to setting the volume level, check that you can still hear your own voice, when speaking normally while listening with the headphones.

Warning! Batteries (battery pack or batteries installed) shall not be exposed to excessive heat such as sunshine, fire or the like.

Warning! To prevent possible hearing damage, do not listen at high volume levels for long periods. As a guide to setting the volume level, check that you can still hear your own voice, when speaking normally while listening with the headphones.

Warning! Batteries (battery pack or batteries installed) shall not be exposed to excessive heat such as sunshine, fire or the like.

Warning! To prevent possible hearing damage, do not listen at high volume levels for long periods. As a guide to setting the volume level, check